

Ironmongery Requirements of a Typical Fire Resisting Door

A Guide for Fire & Accessibility
Compliance (2025)

AN INTRODUCTION TO FIRE DOORS

Buildings are compartmentalised to delay the spread of fire from one area to another. These compartments are usually linked by fire doors to allow the flow of traffic around the building.

A well designed timber fire door will delay the spread of fire and smoke without causing too much hindrance to the movement of people and goods. Every fire door is therefore required to act as a barrier to the passage of smoke and fire to varying degrees, depending upon its location in a building and the fire hazards associated with that building.

FIRE DOORS HAVE TWO IMPORTANT FUNCTIONS:

- 1. WHEN CLOSED THEY FORM A BARRIER TO STOP THE SPREAD OF FIRE**
- 2. WHEN OPENED THEY PROVIDE A MEANS OF ESCAPE.**



IRONMONGERY REQUIREMENTS OF A TYPICAL FIRE DOOR

The main categories of fire doors are FD30 and FD60, which offer 30 and 60 minutes fire protection. The letter S after the 30 or 60 (e.g. FD30S) indicates seals for smoke resistance are required. To determine the FD rating of fire doors, manufacturers have their fire doors assessed by subjecting them to a test procedure as specified in BS EN 1634-1. Tests are made on complete fire door sets: i.e. the fire door and door frame with all the requisite hardware.

Door Hinges

All hinges must comply with BS EN 1935. Intumescent hinge pads must be used for compliance where test evidence requires.

Intumescent Strips

Intumescent strips and cold smoke seals to resist the passage of smoke and fire should be tested to BS 476 Part 22 and Part 31.1 or EN 1634-3. Available Certifire approved.

Intumescent Fire Grilles

Complete with air transfer face plates should comply to BS EN 1634-2, BS 476 Pt 22 & BS EN 1634.

Door Closers

Fire resistant doors must be fitted with a door closer that is successfully tested to BS EN 1154 or BS EN 1155. Certifire is an additional reassurance of a quality product.

Fire Door Signage

Should comply to BS EN 1634-1 & BS 5499

Fire door keep shut
Automatic fire door keep clear

Door Handles

Should comply with BS EN 1906 and if tested as part of door set to BS EN 1634-1.

Locks and Latches

Must comply to BS EN 12209. Intumescent lock or latch kits must be used for compliance.

Automatic Drop Down Seals

These can help in the reduction of contaminants & passage of smoke. They should comply to BS 476 Pt 20 & 22 and BS EN 1634. Available Certifire approved.

Note: From 2 March 2025, BS 476 Parts 6 & 7 are no longer valid in England for reaction-to-fire. **BS 476-22 is only valid until 2 September 2029.** To futureproof your specification, always select hardware that are tested as part of a complete doorset under **EN 1634-1** and classified under **EN 13501-2**.



POOLE WAITE

FIRE DOOR AND SELECTIVE IRONMONGERY RANGE:

a complete range of fire door ironmongery suitable for both commercial and residential properties. Designed, manufactured and tested with clear illustrations, it easily identifies the products intended use, specification and certification.

DOOR HINGES

To ensure compliance with their fire rated performance, fire doors need to be hung with the correct number, size and quantity of hinges. Normally a minimum of 3 are needed, however the manufacturer's instructions should be closely followed.

If fire door evidence requires, hinges installed will need to be fitted with the suitable **intumescent hinge pads** for full compliance, to prevent flames and toxic gases escaping around hinge rebates. BS EN 1935 is the appropriate standard.



Concealed bearing hinge

INTUMESCENT HINGE PADS

These must be used where tested and specified to prevent flames and toxic gases escaping around hinge rebates and to provide a thermal barrier between metal hinge flap and timber frame.

Mono ammonium phosphate (*Interdens*)

- Activation temperature 180°C
- Expands up to 40x in thickness
- Non-compressible

Graphite

- Activation temperature variable 150°C – 190°C
- Expands up to 15/20x in thickness
- Compressible

Always check test data to establish which product the hinge manufacturer or door supplier has had their product tested with.



1mm & 2mm thickness mono-ammonium phosphate intumescent hinge pads (interdens)



0.8mm, 1mm & 2mm thickness graphite intumescent hinge pads

DOOR CLOSING DEVICES

All fire resisting doors (except service ducts and locked cupboards) require appropriately controlled self-closing devices that will effectively close the door from a suitable and tested angle. In certain circumstances, concealed jamb mounted door closers may be specified and in these cases should be capable of closing the door from a desired angle and against a latch bolt or smoke seals if fitted.



The strength and control of the closing device should be compatible with the size of the door and other factors, such as resistance from latch mechanisms, air pressure, heavy traffic use and abusive treatment. The installation of certain door closers with need the suitable intumescent kit when being fitted on fire doors.

They should be tested to **BS EN 1154** or **BS EN 1155**, and **CE marked**. **Certifire approval** is an additional reassurance of a quality product, and UKCA marking is voluntary.

EQUALITY ACT (2010), APPROVED DOCUMENT M & BS 8300

UK fire resistant doors are required to achieve a minimum closing force of between 18 & 26 Newton Metres (Size 3 in accordance with BS EN 1154:1997). The required opening force of door controls to assist less-abled users is:

- Opening force must not exceed **30N** from 0° (closed position) to 30° (open.)
- Opening force must not exceed **22.5N** from 30° to 60°

Other considerations

- Similar to hinges, door closers tested on timber doors are not automatically suitable for steel doors.
- When used on fire doors, the minimum power setting for door closers is Size 3.
- Factors to consider: door location, ironmongery installed and air pressure.



EQUALITY ACT 2010

Newly supplied door closers on fire doors should have the relevant documentation to comply with BS 8300 Part 2.

This requires the opening force of door controls to assist less-abled users, children, the elderly, and disabled.

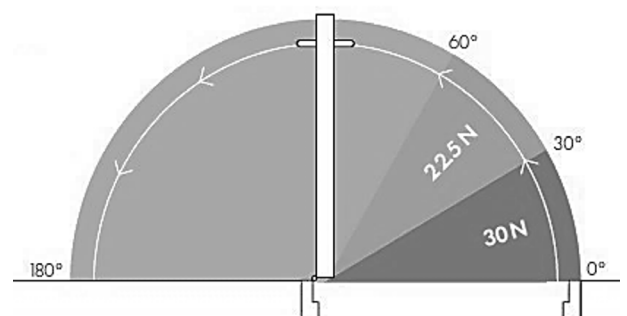

Opening resistance for door closers

DOOR HANDLES

These are a very important component in maintaining fire door integrity and something that is often neglected.

- Standards: BS EN 1906 and BS EN 1634-1
- Handle height: 900 – 1050mm from finished floor level.
- Must be part of tested assembly

Door handles not tested to the required standards can invalidate any fire certification.

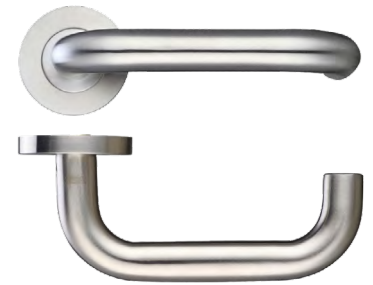

DOOR LOCKS AND LATCHES

Popular options are European DIN size lock cases or UK standard size.

- Standard: BS EN 12209 and Certifire approved when fitted to a fire door.
- Fit correct **intumescent gasket kit** for full compliance.
- Must be CE marked.



FIRE DOOR SIGNAGE

It is important to ensure the correct sign is fixed to the door. Appropriate door signage should comply with BS 5499 and the Safety Signs and Signals Regulations 1996.



INTUMESCENT FIRE AND SMOKE SEALS



The gaps around the side of a door leaf are essential to allow the door to open and close. However, these door edges are the part of a door set most susceptible to penetration by heat and smoke. This is because the pressure of a developing fire drives hot gases between the door and frame, leading to loss of integrity.



Intumescent seals protect these gaps

- PVC strips are rebated into either the door edges or door frame, and are normally visible when opened. They must be applied to both vertical edges and the top, but are not required along the bottom edge.
- Where a door is also required to have a smoke seal, the best solution is to use a combined brush or rubber blade seal.
- Within the PVC sleeve is intumescent material that expands when subjected to heat around 200°C, to fill the gap between the door and the frame thus maintaining its integrity.
- This prevents flames and toxic gases escaping through a closed door, for 30 minutes, 60 minutes, etc. depending on the fire rating.

At no time should the strips be overpainted as this causes them to harden and lose their ability to perform. When fitting strips and seals they must not be altered in shape or size, as this will reduce their effectiveness. They should be tested to **BS 476 part 22 and part 31.1** or **EN 1634-1**.

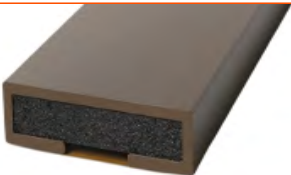
INTUMESCENT PRODUCT	MATERIAL	ACTIVATION TEMPERATURE	EXPANDS
	Graphite based	150-190°C	15-20x
	Sodium silicate	100°C	10x
	Mono ammonium phosphate	180°C	Up to 40x

AUTOMATIC DROP DOWN SEALS

Automatic door bottom seals are mechanically spring loaded seals that lift clear of the floor as the door opens and seal tight when the door is closed. Some automatic door bottom seals are surface mounted whilst other models are fully concealed. They operate over uneven floor surfaces and can be used with threshold plates that offer added protection against rain infiltration where doorways may be exposed to severe weather conditions.

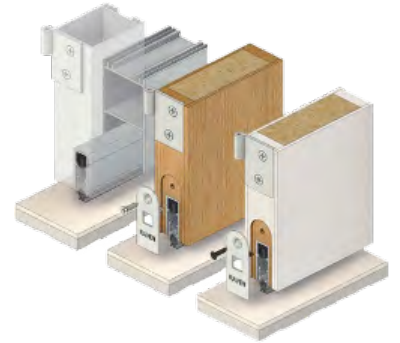

Most door bottom seals are easily adjusted after installation without removing the door. This ensures an optimum seal is achieved and maximum performance is maintained in the event of minor building movement.

AIR TRANSFER VENTS

If an air transfer vent is fitted to the door, the internal grille should comply with **BS EN 1634-2** and **BS 476 Part 22**.

Suitable for internal, surface mounting in doors and walls. The steel construction ensures that the unit is satisfactory not only for Intumescent Fire Grilles but can also be used in standard air transfer applications, utilised with the wide flange border providing adequate clearance for fixing to the surrounding structure. Slimline and unobtrusive, the unit offers a free area around 70% for economical selection.

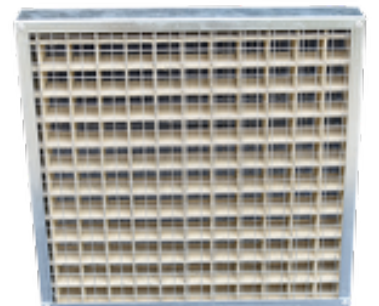

INSTALLATION & INSPECTION REQUIREMENTS

INSTALLATION

- Follow **BS 8214**: Code of Practice for fire door assemblies
- Install all components as tested with no substitutions

DOCUMENTATION & MAINTENANCE

- Comply with **Building Regulation 38**
- Keep inspection logs (including fire & access checks)
- Store evidence of all certification records and corrective actions

ALWAYS USE COMPONENTS AS PART OF A TESTED AND TRACEABLE SYSTEM.

SUBSTITUTIONS MAY INVALIDATE CERTIFICATION

COMPLIANCE CHECKLIST

COMPONENT	REQUIRED STANDARDS	INTUMESCENT NEEDED?	ACCESSIBILITY NOTE	CE MARKING NEEDED?
HINGES	<ul style="list-style-type: none"> BS EN 1935 	Yes (only if fire door test evidence requires)	N/A	Yes
DOOR CLOSERS	<ul style="list-style-type: none"> BS EN 1154 / BS EN 1155 CE or UKCA marked 	Yes	Must meet 30N/22.5N force limits.	Yes
HANDLES	<ul style="list-style-type: none"> BS EN 1906 BS EN 1634-1 	No	900 – 1050mm height	No
LOCKS & LATCHES	<ul style="list-style-type: none"> BS EN 12209 CE marked 	Yes	Ensure usability	Yes
FIRE DOOR SIGNAGE	<ul style="list-style-type: none"> BS EN 1634-1 BS 5499 	No	N/A	No
SMOKE SEALS	<ul style="list-style-type: none"> BS 476 part 22 & 31.1 EN 1634-1 	Yes	Combined seal preferred	No
AIR TRANSFER VENTS	<ul style="list-style-type: none"> BS EN 1634-2 BS 476 Part 22 	Yes	N/A	

This guide is for reference only and should not be relied upon standards and certifications may change at any time.